

Christie CP2210

Digital cinema projection
Color Correction/Timing rooms
Digital intermediate suites
Executive screening rooms
Post production



Powerful. Compact. Reliable.

The Christie CP2210 is the most compact digital cinema projector in the world and the projector of choice for the world's leading post-production facilities and exhibitors where booth space is at a premium. Coming from a heritage in cinema, we know what it takes to keep production and installation schedules on track. The reliability of our solutions mean that in the most critical situations, you can depend on Christie.

As part of the Christie Solaria Series of digital cinema projectors, the Christie CP2210 is based on Series 2 DLP® technology from Texas Instruments. This technology is designed to be compliant with the Digital Cinema Initiatives (DCI) specification.

CHRISTIE®



▲ For screens up to 45 feet



Christie CP2210

127-001102-01

Purpose-built for long-term reliability, the Christie CP2210 is the industry's most compact DCI compliant projector available today. At less than 100 pounds, and with heat extraction optional... this powerful compact projector can be installed nearly anywhere.

Based on .98" DLP Cinema® technology, the Christie CP2210 uses high efficiency, long lasting CDXL-SD series Xenon lamps as well as the CXL-14M, a new lamp designed for long life and low power consumption. The competition requires higher wattage lamps for the same light output, giving Christie clear advantage on cost of ownership and lumens per watt.

A robust and reliable addition, the Christie CP2210 features a motorized lensing solution and a selection of eight new zoom lenses to guarantee the right lens solution for virtually any auditorium with absolutely no need for resizing or scaling. It is the projector of choice for small screens and post production applications that demand performance and reliability in a small, affordable package.

2K Series 2 DLP Cinema®
Designed to be DCI compliant
3D ready
Lowest cost of ownership
Accessories - for easy integration into any environment, Christie's full range of digital cinema accessories includes the Christie Cine-IPM 2K for alternative content, the Christie Multimedia Adapter for economical audio and video scaling, the Christie ACT automation control system, and a full suite of lenses and lamps.
Standard support for HDCP and SNMP

Split power operation for use with UPS
Local control via flexible Touch Panel Controller (TPC) and full access from anywhere via web based VNC
One-piece compact design for flexible mounting and installation
Rear access for quick and easy lamp changes
New Intelligent Lens System (ILS),™ custom designed for cinema, for reliable motorized lens operation
In its standard configuration, the Christie CP2210 requires no heat extraction, an optional duct is available if desired

Specifications	CP2210	
Brightness ¹	lamp	<ul style="list-style-type: none"> • 1.4kW (CXL-14M) 003-003066-01 • 1.8kW (CDXL-18SD) 003-002742-01 • 2.0kW (CDXL-20SD) 003-001976-01
	nominal	• ~12,000 lumens
screen size	• <45' maximum screen size ¹	
Contrast ratio	• >2000:1 full field on/off	
Digital micromirror device	<ul style="list-style-type: none"> • 0.98" 2K 3-chip DMD DLP Cinema® • 2048 x 1080 pixels 	
Input line voltage	• Single phase 220V	
Number of colors	• 35.2 trillion	
Lenses	• See christiedigital.com or the Entertainment Solutions brochure for a complete list of lens options.	
Power supply	• 1kW-2.1kW low-ripple switch mode lamp power supply	
Weight	• As installed: 96lb max (43.5kg)	
Accessories	<ul style="list-style-type: none"> • 90 degree extraction duct adapter 119-103105-01 • Lens blinder kit 119-102101-01 • Rack mount stand (fully assembled) 108-282101-02 • Rear feet lock downs 119-100101-01 	

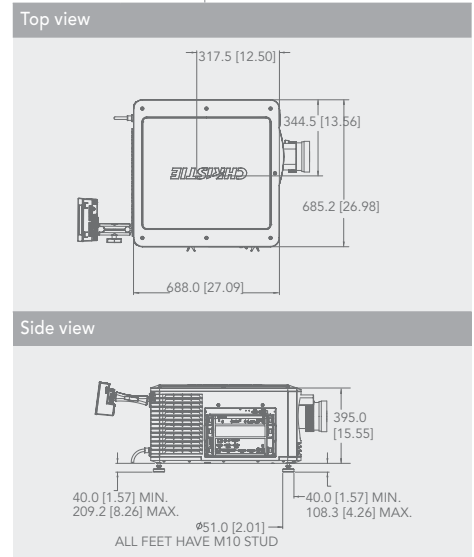

¹ Maximum screen size depends upon various factors such as screen gain, lamp age, geometry, etc. Consult your Christie rep for detailed analysis. Measured at screen center.

Corporate offices

Christie Digital Systems USA, Inc
USA – Cypress
ph: 714 236 8610

Christie Digital Systems Canada Inc.
Canada – Kitchener
ph: 519 744 8005

Worldwide offices

United Kingdom
ph: +44 (0) 118 977 8000

Germany
ph: +49 2161 664540

France
ph: +33 (0) 1 41 21 44 04

Spain
ph: +34 91 633 9990

Eastern Europe and Russian Federation
ph: +36 (0) 1 47 48 100

United Arab Emirates
ph: +971 (0) 4 299 7575

India
ph: (080) 41468941 – 48

Singapore
ph: +65 6877 8737

Independent sales consultant offices

Italy
ph: +39 (0) 2 9902 1161

South Africa
ph: +27 (0) 317 671 347

China (Shanghai)
ph: +86 21 6278 7708

China (Beijing)
ph: +86 10 6561 0240

Japan (Tokyo)
ph: 81 3 3599 7481

Korea (Seoul)
ph: +82 2 702 1601



DLP Cinema® Technology
2009 Academy Scientific and Engineering Award for Color Accuracy

A.M.P.A.S.® Recipients of the 2009 Academy Plaque are: D. Scott Dewald, Greg Pettitt, Brad Walker and Bill Werner.



For the most current specification information, please visit www.christiedigital.com